



NICK SHABA
ASSOCIATE

JORDAN JABBORI
SENIOR DIRECTOR

6476 Orchard Lake Road | Suite A | West Bloomfield | Michigan | 48322

nshaba@cmprealestategroup.com

jjabbori@cmprealestategroup.com

Phone: 248.538.2000 | www.cmprealestategroup.com

PROPERTY INFORMATION

Property Address	17300 23 Mile Road
City/Township	Macomb
Proposed Building Size	2,100 SF with Drive Thru
Parcel Size	0.90 AC Pad Available
Ground Lease Rate	Contact Broker
Pad Site Sale Price	Contact Broker
Parking	30 +/- Parking Spaces

DEMOGRAPHICS (FIVE-MILE RADIUS)

 POPULATION 167,142 PEOPLE	 MEDIAN AGE 41.3 YEARS OLD
 HOUSEHOLDS 62,309	 CONSUMER SPENDING \$2.2 BILLION ANNUALLY
 AVG HOUSEHOLD INCOME \$106,038/ANNUALLY	 DAYTIME EMPLOYEES 62,508 EMPLOYEES

AREA TENANTS & EMPLOYERS



PROPERTY HIGHLIGHTS

- Join Jax Kar Wash along 23 Mile road just west of Romeo Plank in Macomb Township, MI.
- Proposed 2,100 SF +/- Freestanding building available for ground lease or Build-to-Suit.
- Situated along 23 Mile road, this opportunity presents excellent visibility and accessibility for any retail or medical user to take advantage of.
- In addition to Ascension hospital down the street, the site is nestled between big box retailers and hundreds of industrial companies.

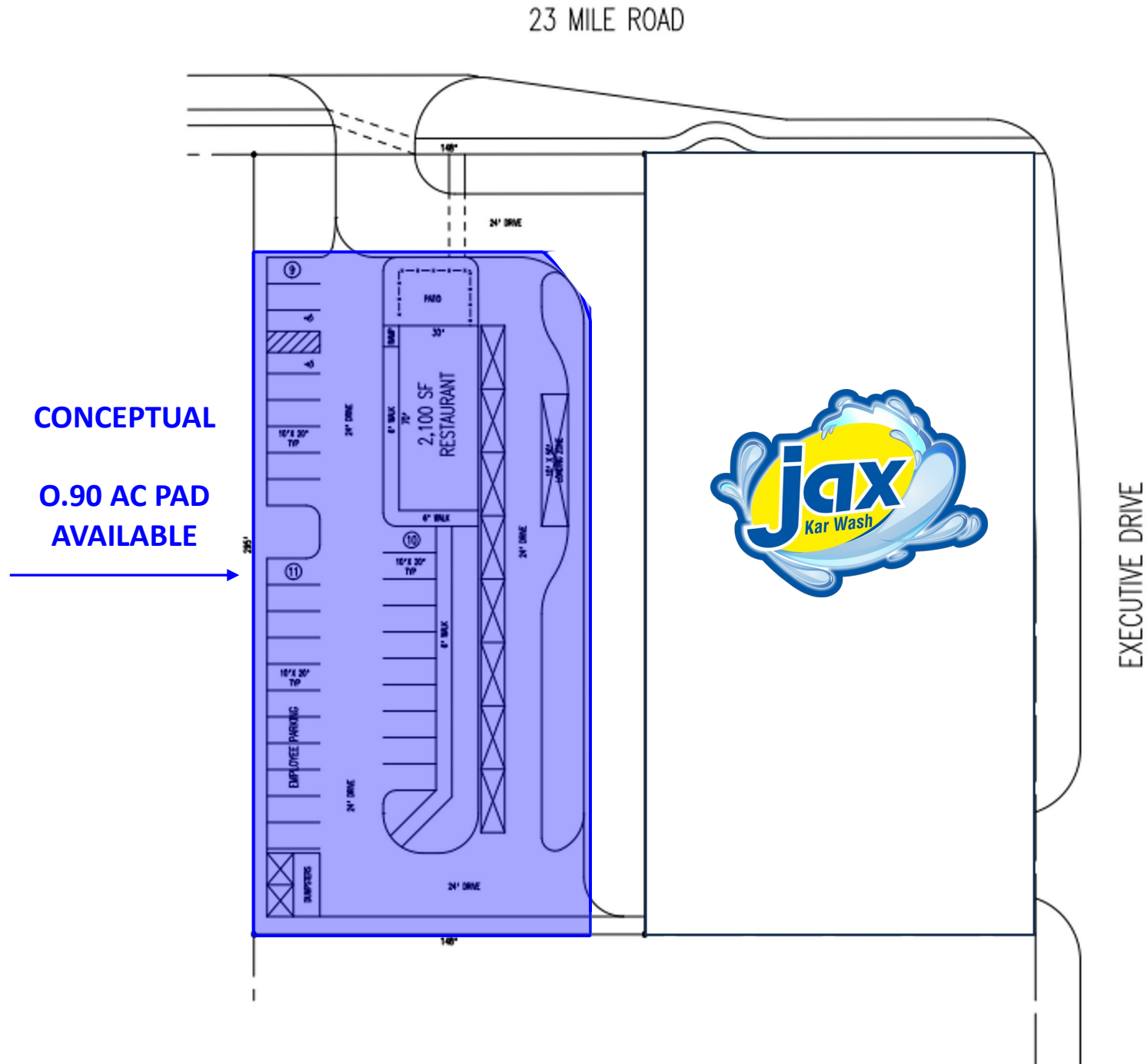



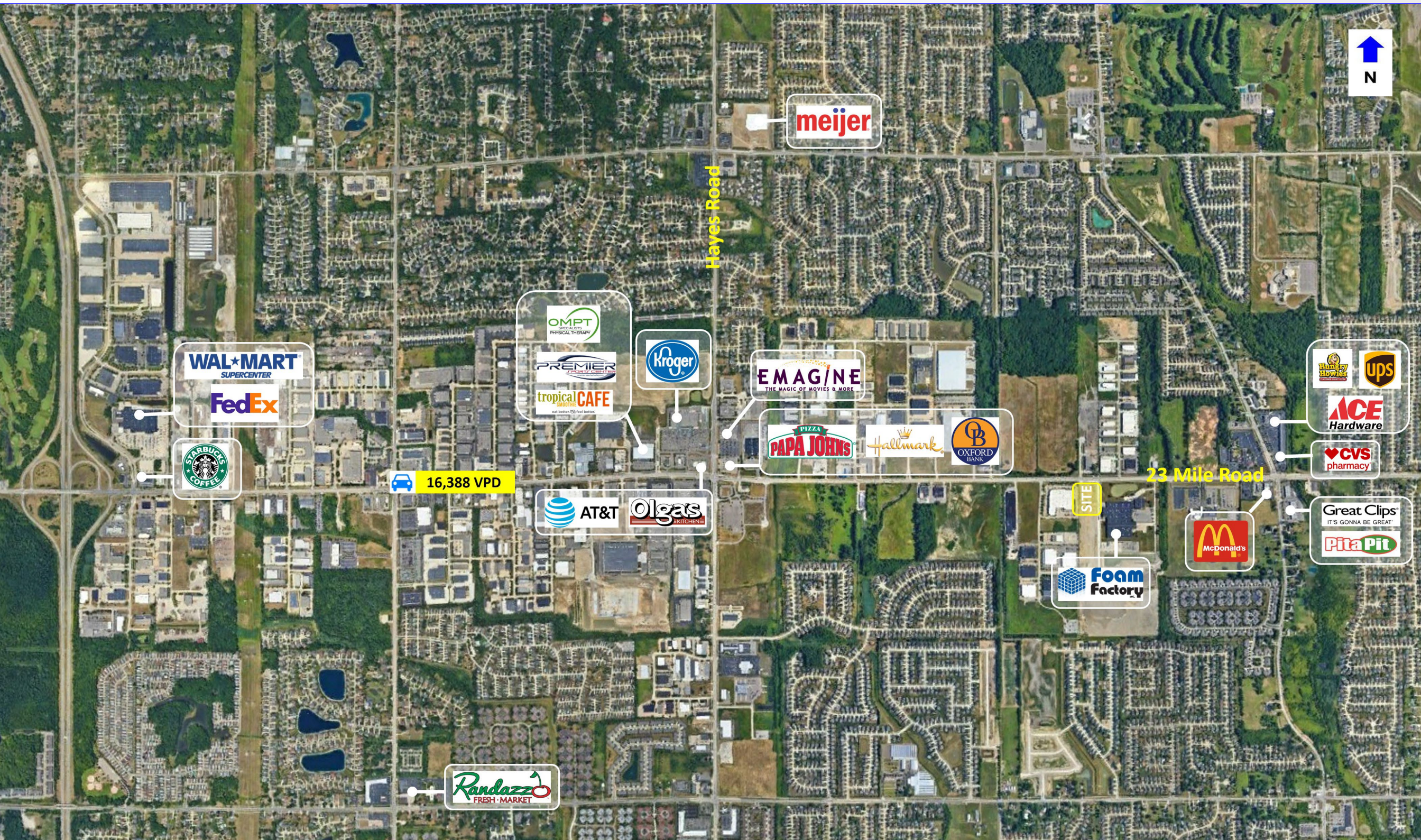

meijer

WAL*MART
SUPERCENTER
FedEx

STARBUCKS
COFFEE

16,388 VPD

OMPT
PHYSICAL THERAPY
PREMIER
TROPICAL CAFE

Kroger

EMAG/NE
THE MAGIC OF MOVIES & MORE

PAPA JOHN'S

Hallmark

OXFORD
BANK

AT&T

Olgas
KITCHENS

SITE

23 Mile Road

Foam
Factory

McDonald's

Hungry Howies
UPS
ACE
Hardware

CVS
pharmacy

Great Clips
Pita Pit

Randazzo
FRESH MARKET



POPULATION	1 MILE	3 MILE	5 MILE
2010 Population	8,337	76,107	154,160
2023 Population	9,400	81,897	167,142
2028 Population Projection	9,573	82,756	169,118
Annual Growth 2010-2022	1.00%	0.60%	0.60%
Annual Growth 2022-2027	0.40%	0.20%	0.20%
Median Age	39.6	40.2	41.3
Bachelor's Degree or Higher	38%	33%	30%

HOUSEHOLDS	1 MILE	3 MILE	5 MILE
2010 Households	2,730	25,585	57,301
2023 Households	3,081	27,647	62,309
2028 Household Projection	3,137	27,952	63,066
Owner Occupied Households	3,008	26,330	51,307
Renter Occupied Households	129	1,622	11,759
Avg Household Income	\$131,173	\$119,813	\$106,038
Median Household Income	\$116,503	\$106,601	\$89,330

POPULATION BY RACE	1 MILE	3 MILE	5 MILE
White	7,957	71,063	141,149
Black	680	4,687	13,977
American Indian/Alaskan Native	22	180	459
Asian	534	4,229	7,817
Hawaiian & Pacific Islander	2	38	69
Two or More Races	207	1,701	3,671
Hispanic Origin	199	2,191	4,717

INCOME	1 MILE	3 MILE	5 MILE
\$25,000 - 50,000	349	3,358	10,071
\$50,000 - 75,000	358	3,574	9,732
\$75,000 - 100,000	365	4,031	9,124
\$100,000 - 125,000	487	4,039	8,143
\$125,000 - 150,000	439	3,713	6,488
\$150,000 - 200,000	523	4,394	7,285
\$200,000+	413	2,744	5,344

DAYTIME EMPLOYMENT	ONE MILE			THREE MILE			FIVE MILE		
	TOTAL EMPLOYEES	TOTAL BUSINESSES	EMPLOYEES PER BUSINESS	TOTAL EMPLOYEES	TOTAL BUSINESSES	EMPLOYEES PER BUSINESS	TOTAL EMPLOYEES	TOTAL BUSINESSES	EMPLOYEES PER BUSINESS
Service-Producing Industries	1,566	241	6	11,644	1,665	7	50,638	6,381	8
Trade Transportation & Utilities	471	28	17	2,677	252	11	13,241	925	14
Information	20	6	3	180	23	8	822	90	9
Financial Activities	76	18	4	996	187	5	4,516	686	7
Professional & Business Services	126	30	4	1,175	243	5	4,168	761	5
Education & Health Services	549	125	4	3,063	610	5	11,880	2,697	4
Leisure & Hospitality	212	16	13	2,060	159	13	9,155	558	16
Other Services	100	16	6	1,059	179	6	4,165	576	7
Public Administration	12	2	6	434	12	36	2,691	88	31
Goods-Producing Industries	198	34	6	4,297	376	11	11,870	905	13
Natural Resources & Mining	1	1	1	23	8	3	40	13	3
Construction	56	20	3	1,559	224	7	3,553	515	7
Manufacturing	141	13	11	2,715	144	19	8,277	377	22
Total	1,764	275	6	15,941	2,041	8	62,508	7,286	9

EXCLUSIVELY LISTED BY:

NICK SHABA

ASSOCIATE

nshaba@cmprealestategroup.com

JORDAN JABBORI

SENIOR DIRECTOR

jjabbori@cmprealestategroup.com

CONTACT US:



6476 Orchard Lake Road, Suite A
West Bloomfield, Michigan 48322



(P): 248.538.2000
(F): 248.538.9905



Email: info@cmprealestategroup.com
Website: www.cmprealestategroup.com

The information contained in this Marketing Package does not purport to provide a complete or fully accurate summary of the Property or any of the documents related thereto, nor does it purport to all inclusive or to contain all the information, which a potential tenant may need or desire. All information contained herein has been secured by sources we believe to be reliable; however, CMP Real Estate Group, LLC ("Broker") has not independently verified any of the information. This Marketing Package prepared by Broker, does not constitute an indication that there has been no change in the Property or the market conditions since the date of preparation of the information herein. Additional information and an opportunity to inspect the Property will be made available to the interested and qualified prospective tenant/purchaser, if available.

Neither Owner nor Broker nor any of there respective officers, Agents or principals has made or will make any representations or warranties, express or implied, as to the accuracy or completeness of this Marketing Package or any of its contents, and no legal commitment or obligation shall arise by reason of the Marketing Package or its contents. Analysis and verification of the information contained in the Marketing Package is solely the responsibility of the prospective tenant/purchaser.

Owner and Broker expressly reserve the right, at their sole discretion, to reject any or all expressions of interest or offers to lease/purchase the Property and/or terminate discussions with any entity at anytime with or without notice. Owner has no legal commitment or obligation to any entity reviewing this Marketing Package or making an offer to lease/purchase the Property unless and until such lease/sale of the Property is approved by Owner in its sole discretion, a written agreement for lease/purchase of the Property unless and until such sale of the Property is approved by Owner in its sole discretion, a written agreement for leased/purchase of the Property has been fully delivered, and approve by Owner, its legal counsel and any conditions to the Owner's obligations thereunder have been satisfied or waived.



RETAIL LEASING

*Landlord Representation
& New Project Leasing*



TENANT REPRESENTATION

*Site Selection &
Negotiations*



INVESTMENT SALES

STNL & Multi-Tenant, Multi-Family, Carwashes, etc.



ACQUISITIONS/DISPOSITIONS

Single & Full Portfolio Transactions



MARKET ANALYSIS

Market Research & Site Evaluations



NATIONAL RELATIONSHIPS

Retailers & Investors across the U.S.



TEAMWORK

Innovative Solutions



SHARED DATABASE

Retailers & Investors across the U.S.